

Stress Analysis Report

Autodesk®

Analyzed File:	
Autodesk Inventor Version:	2012 (Build 160160000, 160)
Creation Date:	10/05/2013, 15:53
Simulation Author:	Petei7Ivy
Summary:	

☐ Project Info (iProperties)

☐ Summary

Author	Petei7Ivy
--------	-----------

☐ Project

Designer	Petei7Ivy
Cost	£0.00
Date Created	10/05/2013

☐ Status

Design Status	WorkInProgress
---------------	----------------

☐ Physical

Material	Default
Density	1 g/cm ³
Mass	11.225 kg
Area	1317800 mm ²
Volume	11225000 mm ³
Center of Gravity	x=675 mm y=225 mm z=9.31893 mm

Note: Physical values could be different from Physical values used by FEA reported below.

☐ Simulation:2

General objective and settings:

Design Objective	Single Point
Simulation Type	Static Analysis
Last Modification Date	10/05/2013, 15:52
Detect and Eliminate Rigid Body Modes	No

Advanced settings:

Avg. Element Size (fraction of model diameter)	0.1
Min. Element Size (fraction of avg. size)	0.2
Grading Factor	1.5

Max. Turn Angle	60 deg
Create Curved Mesh Elements	Yes

Material(s)

Name	Default	
General	Mass Density	1 g/cm ³
	Yield Strength	10.5 MPa
	Ultimate Tensile Strength	10.5 MPa
Stress	Young's Modulus	2.412 GPa
	Poisson's Ratio	0.25 ul
	Shear Modulus	0.9648 GPa
Stress Thermal	Expansion Coefficient	0 ul/c
	Thermal Conductivity	0 W/(m K)
	Specific Heat	0 J/(kg c)
Part Name(s)	Part4	

Operating conditions

Force:1

Load Type	Force
Magnitude	1800.000 N
Vector X	0.000 N
Vector Y	0.000 N
Vector Z	1800.000 N

Selected Face(s)

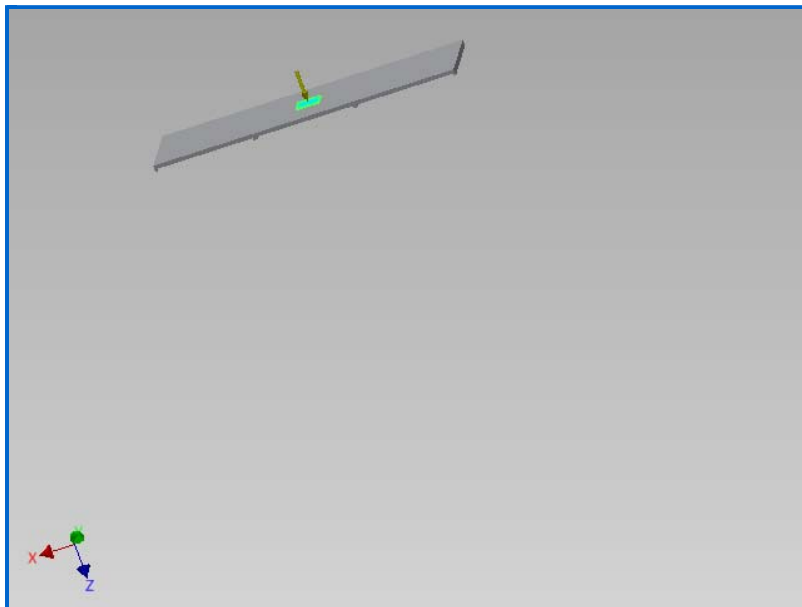

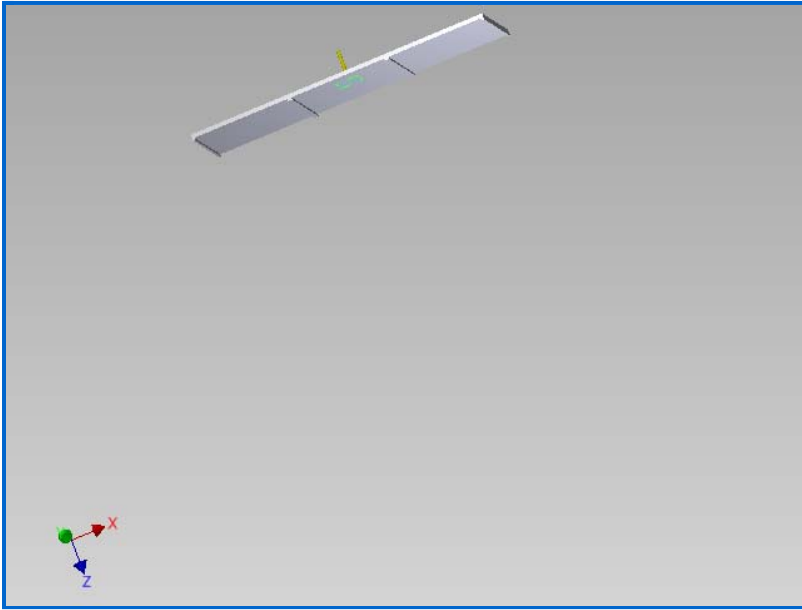

Fixed Constraint: 1

Constraint Type Fixed Constraint

Selected Face(s)

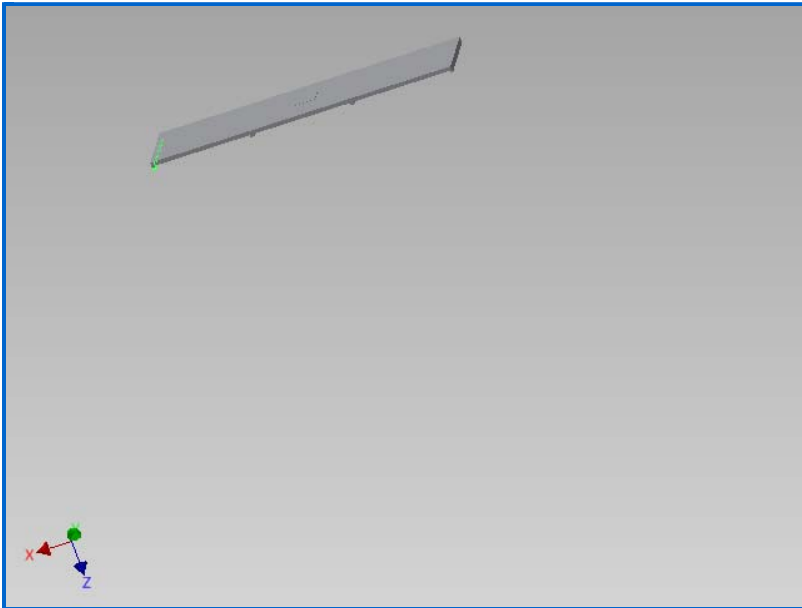

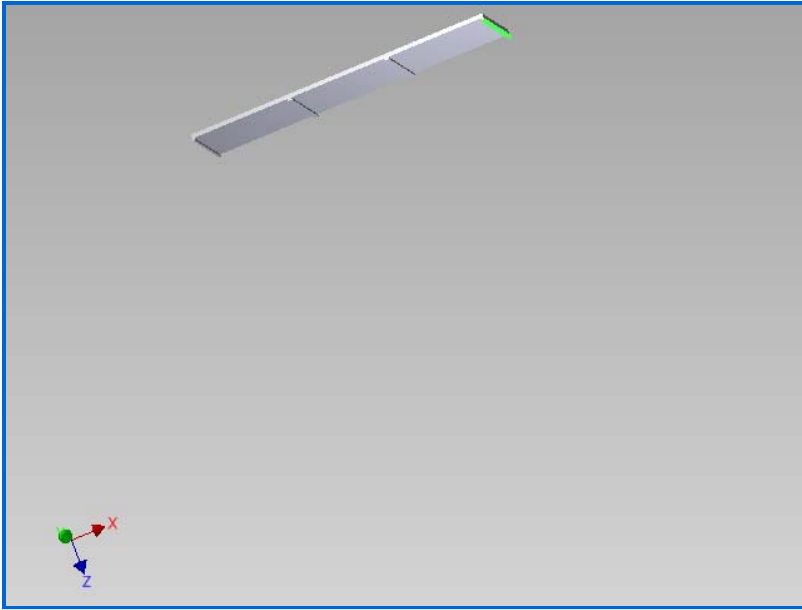

Fixed Constraint:2

Constraint Type Fixed Constraint

Selected Face(s)

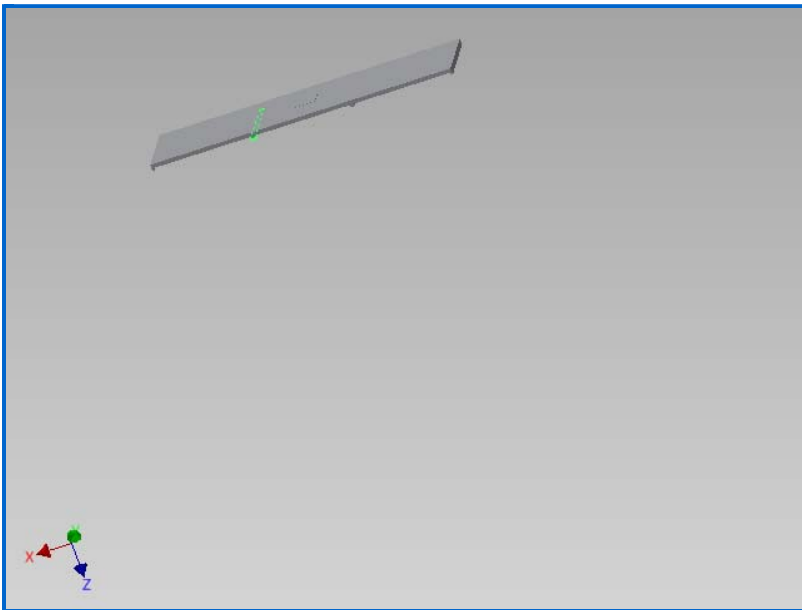

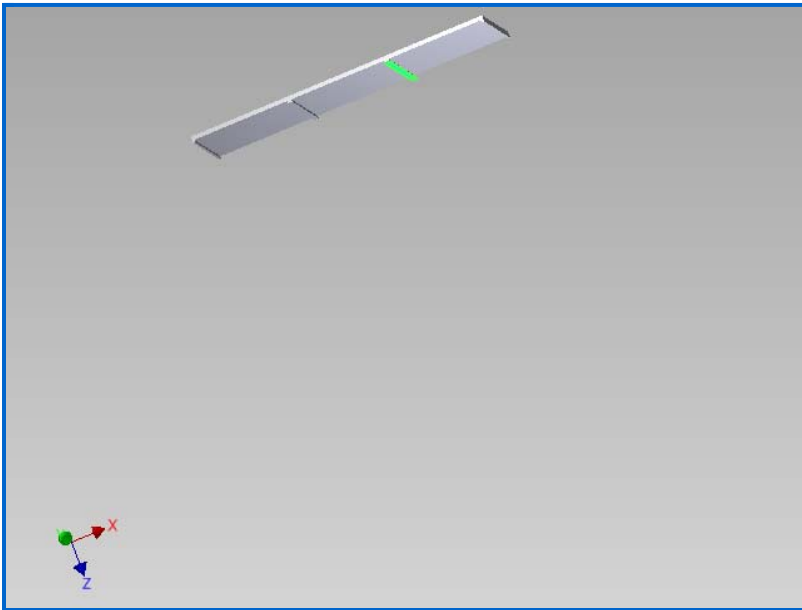

Fixed Constraint:3

Constraint Type Fixed Constraint

Selected Face(s)

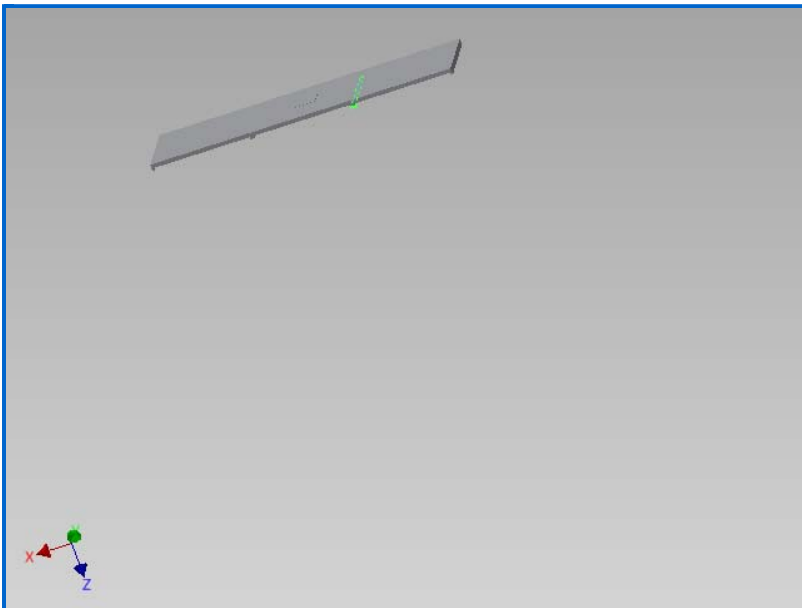

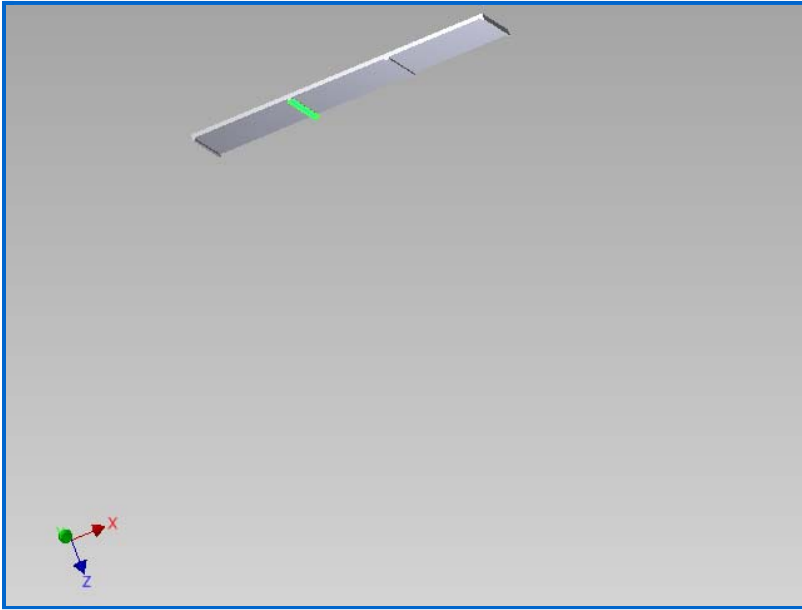

Fixed Constraint:4

Constraint Type Fixed Constraint

Selected Face(s)

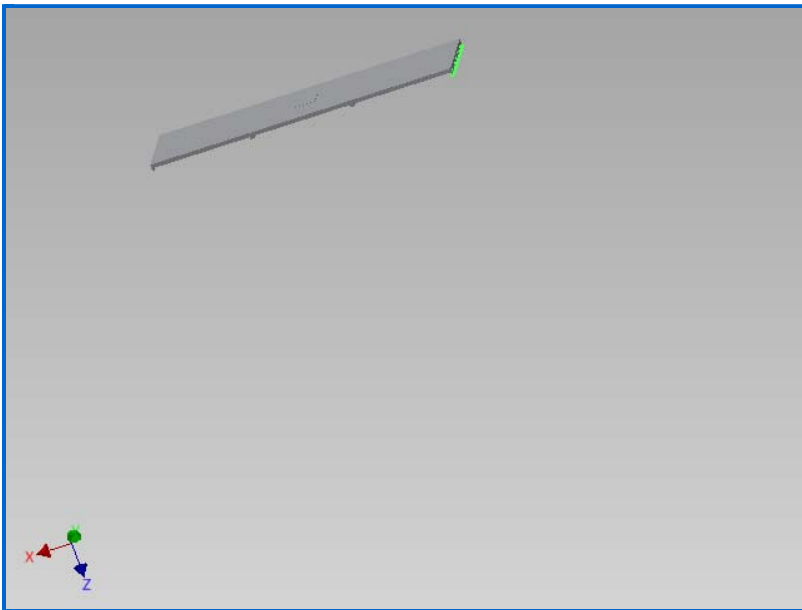

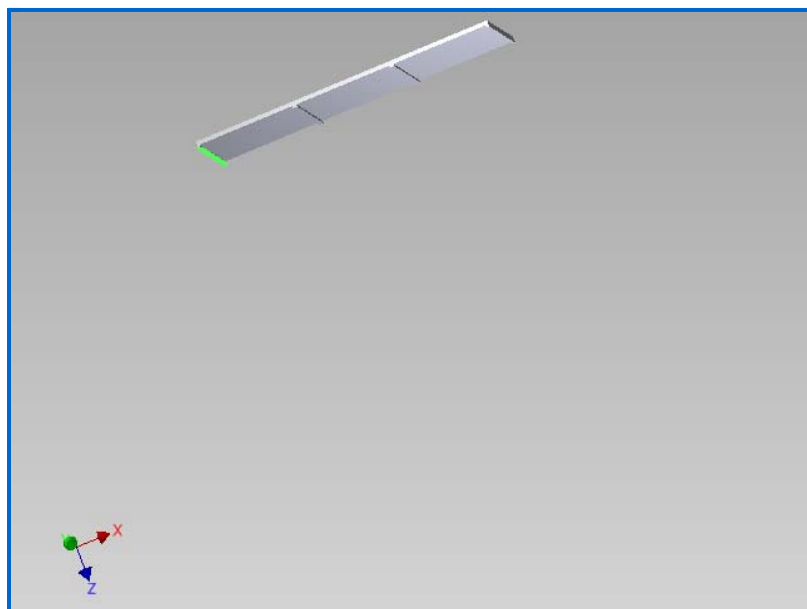

Results

Reaction Force and Moment on Constraints

Constraint Name	Reaction Force		Reaction Moment	
	Magnitude	Component (X,Y,Z)	Magnitude	Component (X,Y,Z)
Fixed Constraint:1	304.138 N	303.995 N	6.08335 N m	0.808847 N m
		3.57502 N		-5.66622 N m
		-8.62226 N		-2.0608 N m
Fixed Constraint:2	1995.43 N	-1785.6 N	72.6211 N m	-0.558174 N m
		0 N		-72.619 N m
		-890.717 N		0 N m
Fixed Constraint:3	1986.44 N	1775.21 N	73.3568 N m	0 N m
		0 N		73.3408 N m
		-891.381 N		-1.53208 N m
Fixed Constraint:4	293.383 N	-293.192 N	5.90648 N m	-0.762799 N m
		-4.8504 N		5.58958 N m
		-9.42125 N		-1.74964 N m

Result Summary

Name	Minimum	Maximum
Volume	11225000 mm ³	
Mass	11.225 kg	
Von Mises Stress	0.00524 MPa	6.52619 MPa
1st Principal Stress	-1.78868 MPa	4.86456 MPa
3rd Principal Stress	-7.82268 MPa	0.876923 MPa
Displacement	0 mm	1.87515 mm
Safety Factor	1.6089 ul	15 ul
Stress XX	-6.7035 MPa	4.86452 MPa
Stress XY	-0.764651 MPa	0.770631 MPa
Stress XZ	-2.88835 MPa	2.35818 MPa
Stress YY	-3.61544 MPa	3.78755 MPa
Stress YZ	-1.84853 MPa	1.37158 MPa
Stress ZZ	-4.99834 MPa	2.57013 MPa

X Displacement	-0.119172 mm	0.119089 mm
Y Displacement	-0.0634862 mm	0.0635204 mm
Z Displacement	-0.0452384 mm	1.87514 mm
Equivalent Strain	0.00000181936 ul	0.00252577 ul
1st Principal Strain	-0.00000997074 ul	0.00163605 ul
3rd Principal Strain	-0.00284678 ul	-0.00000137122 ul
Strain XX	-0.00228851 ul	0.00163604 ul
Strain XY	-0.000396274 ul	0.000399374 ul
Strain XZ	-0.00149686 ul	0.00122211 ul
Strain YY	-0.00102035 ul	0.0010728 ul
Strain YZ	-0.000957985 ul	0.000710809 ul
Strain ZZ	-0.00170475 ul	0.00103563 ul

☐ Figures

☐ Von Mises Stress

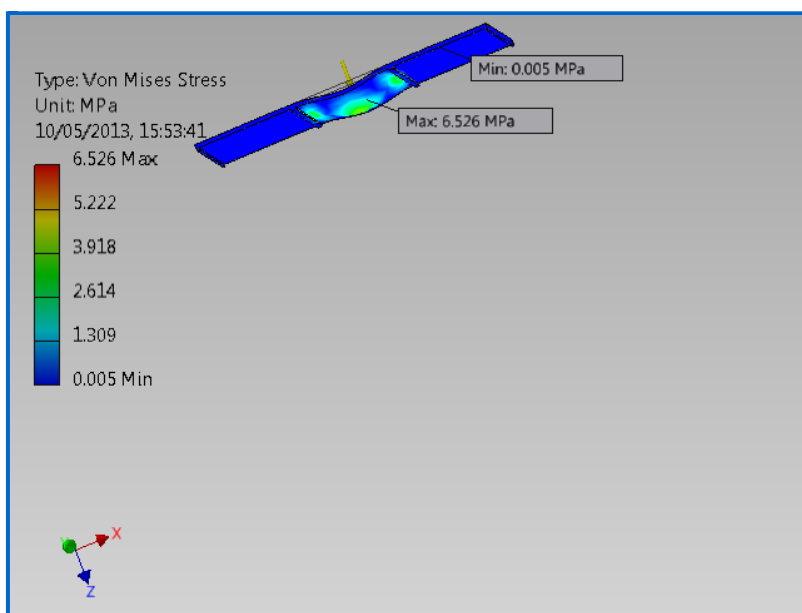
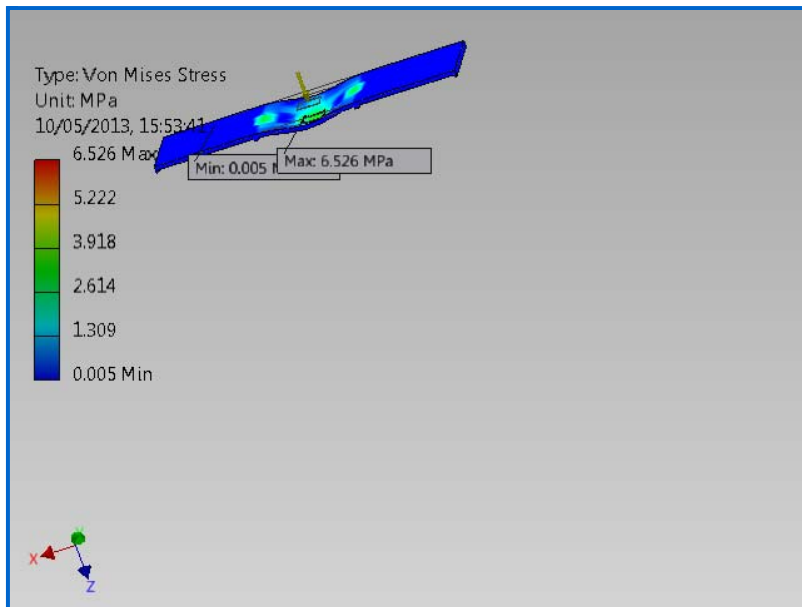

☐ 1st Principal Stress

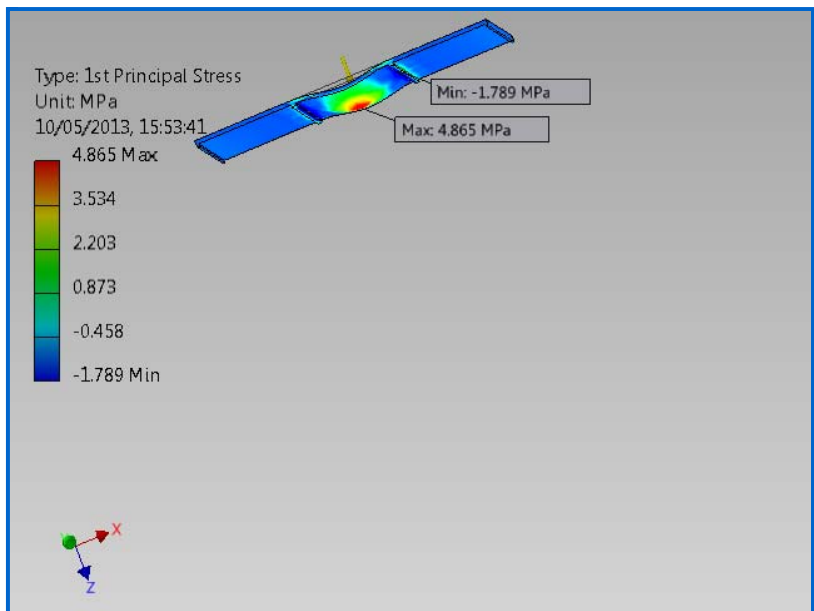
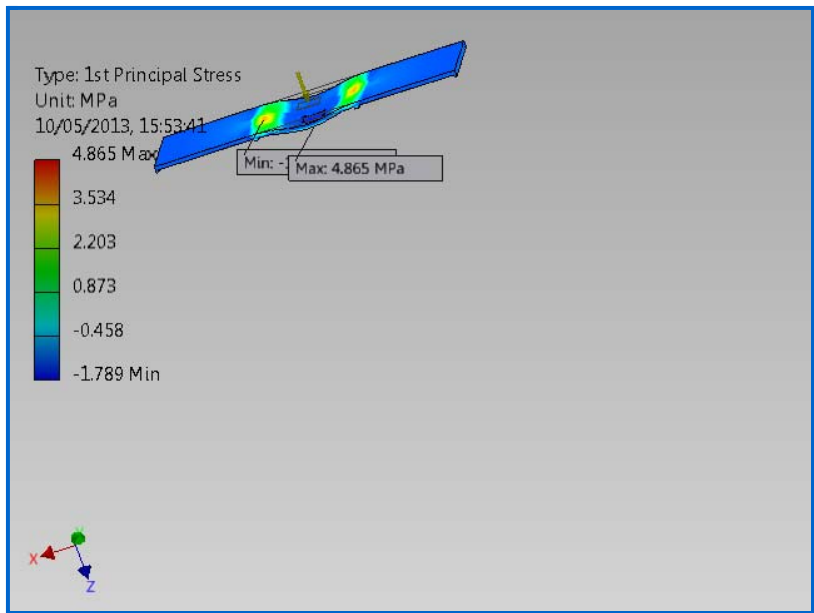

3rd Principal Stress

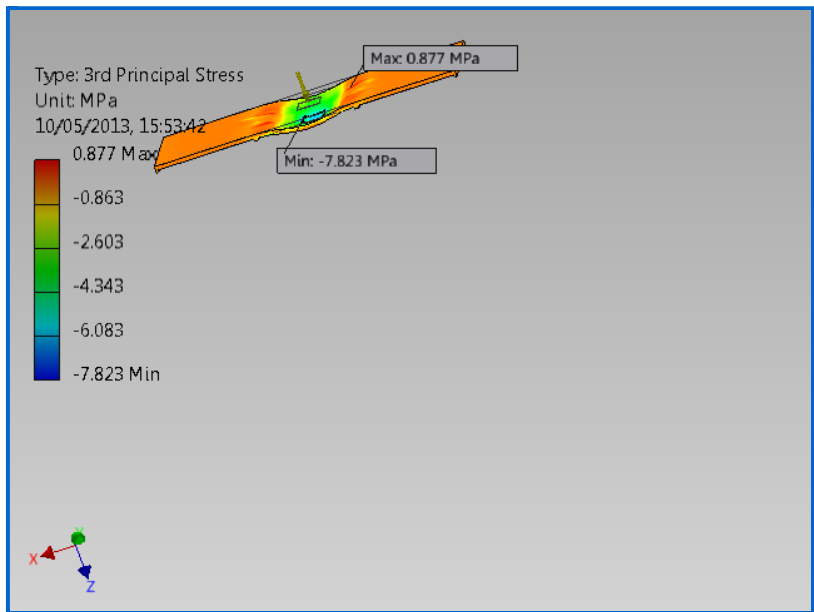

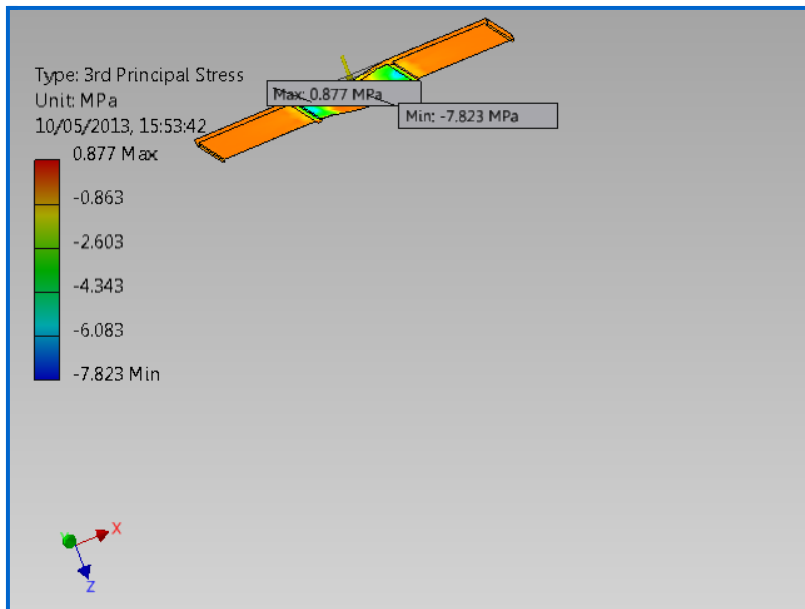

▣ Displacement

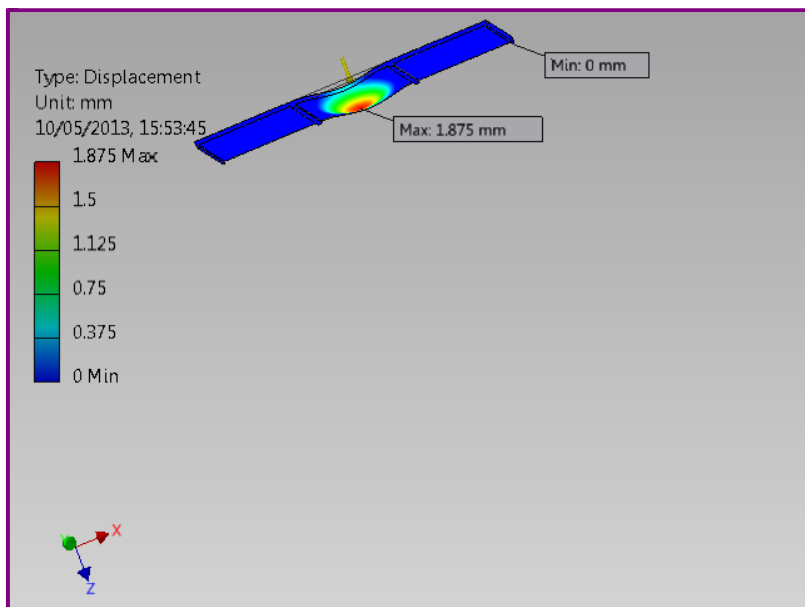
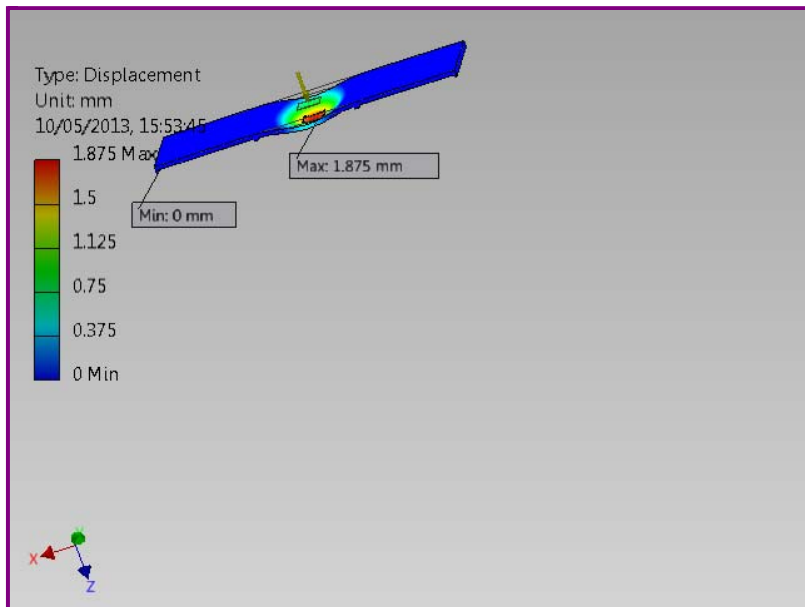

☐ Safety Factor

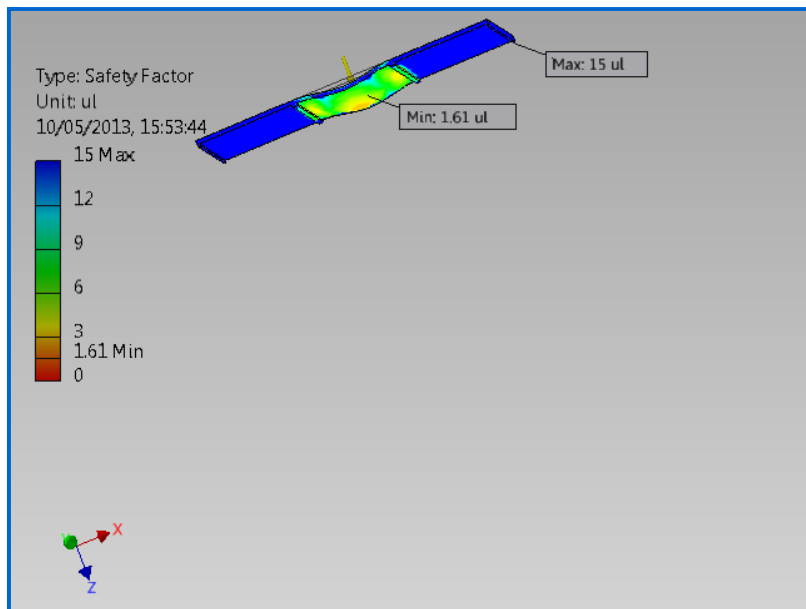
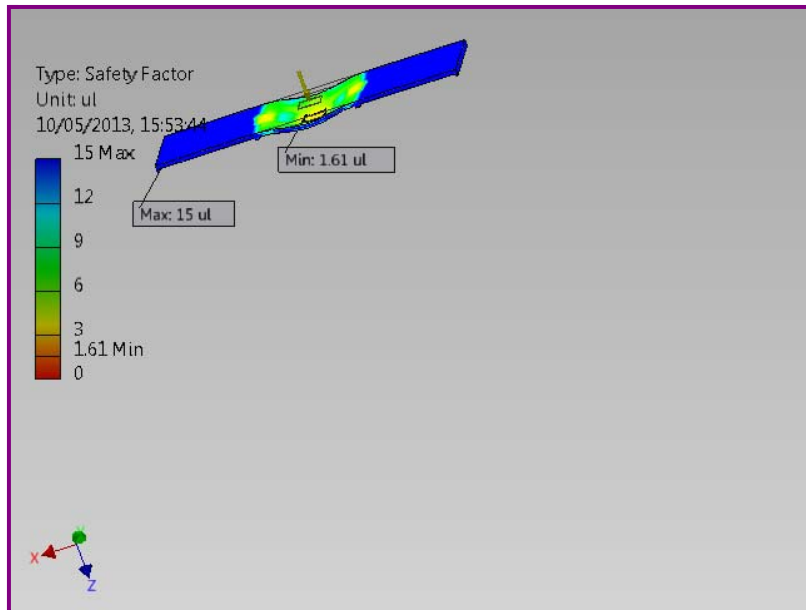

☐ Stress XX

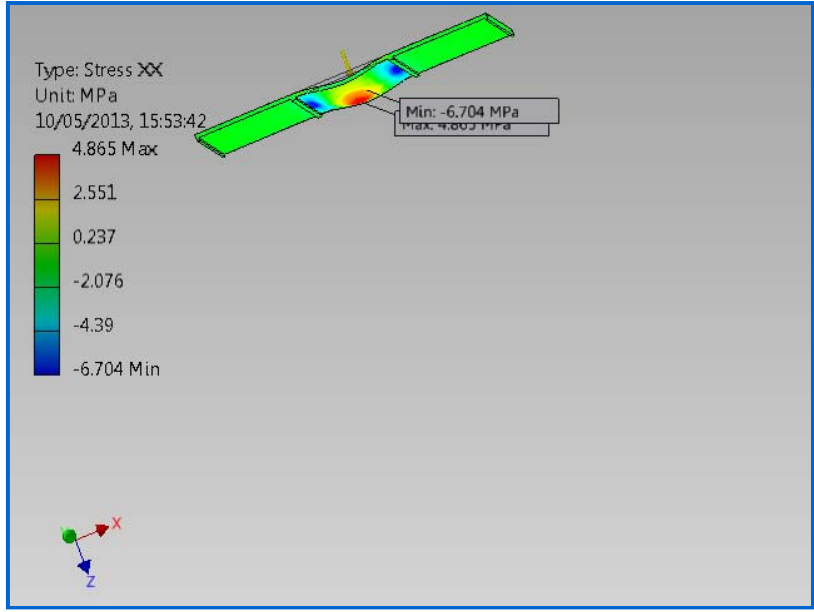
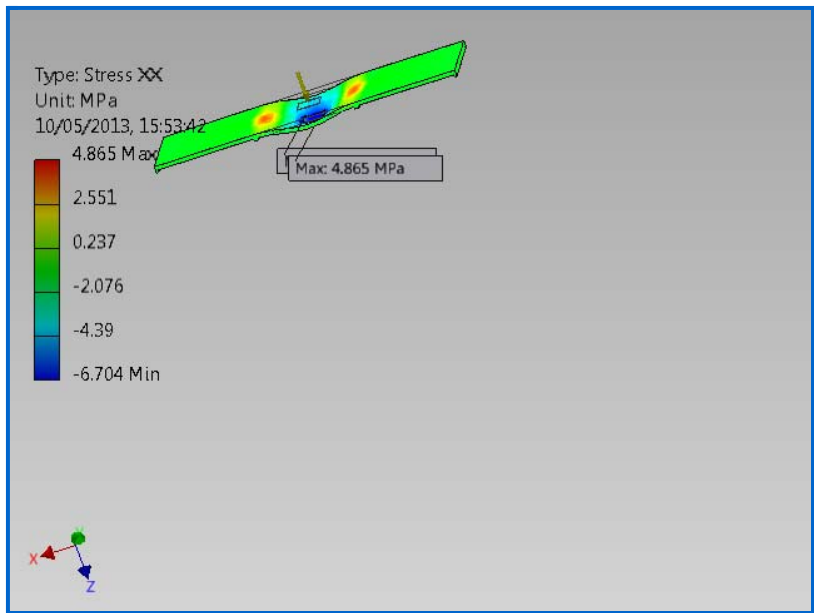

☐ Stress XY

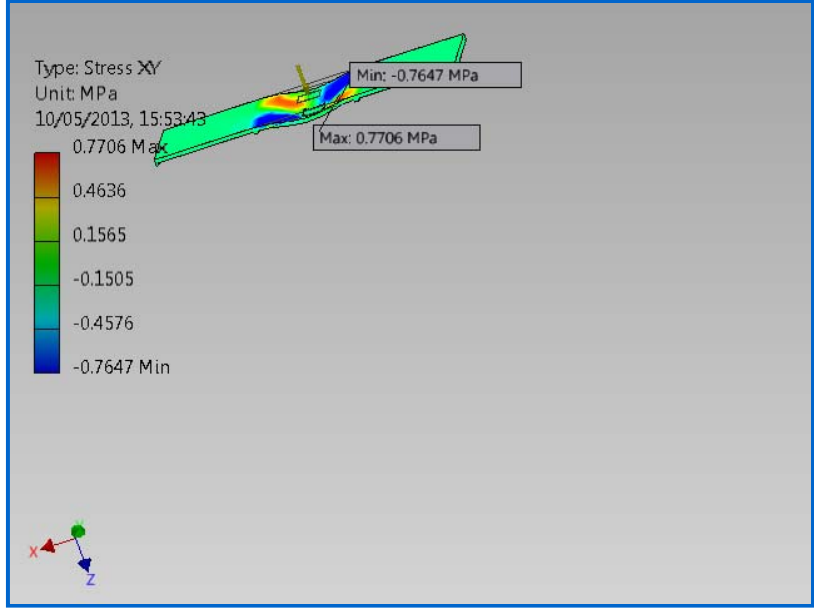

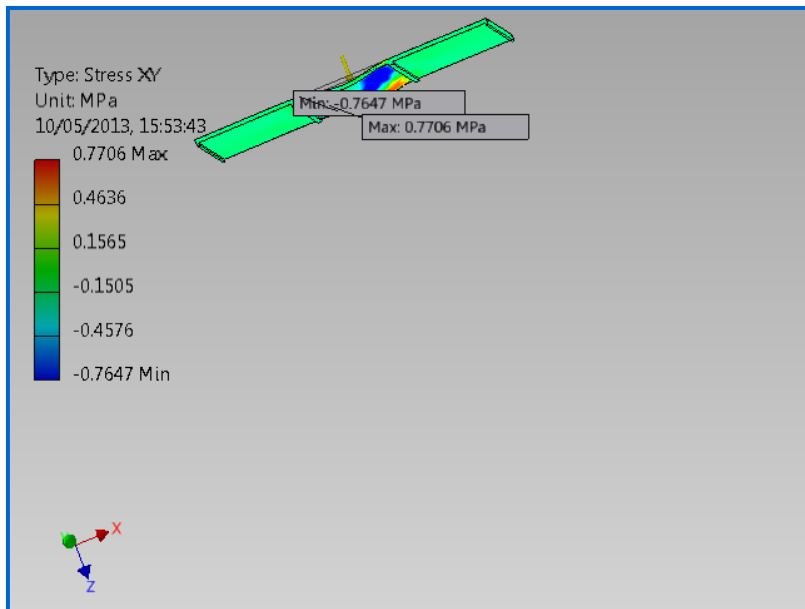

☐ Stress XZ

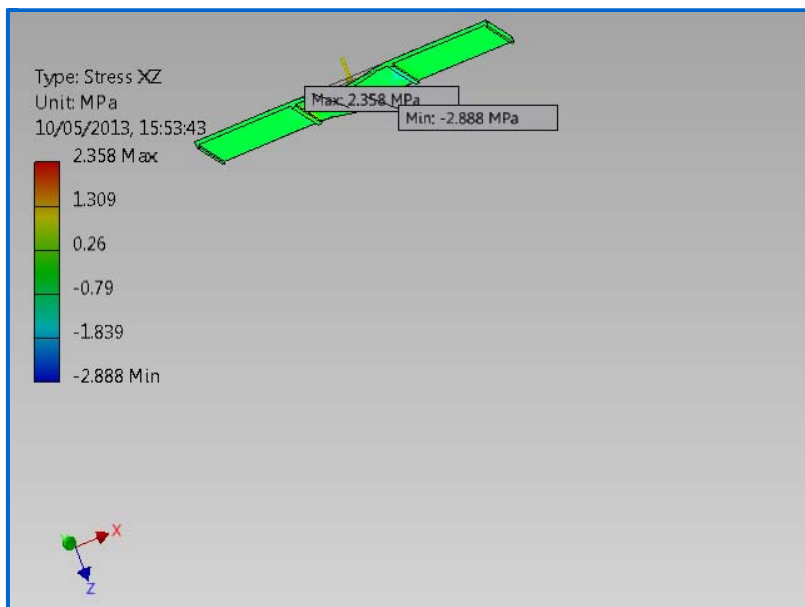
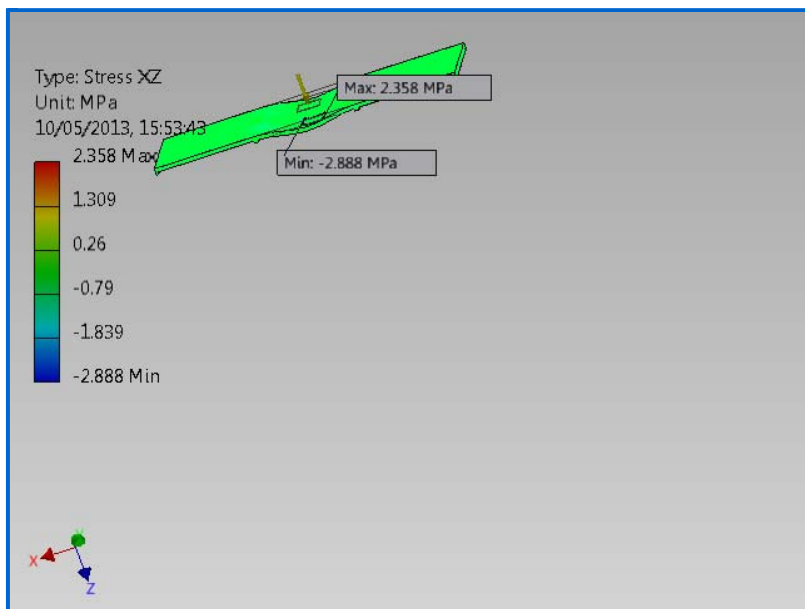

☐ Stress YY

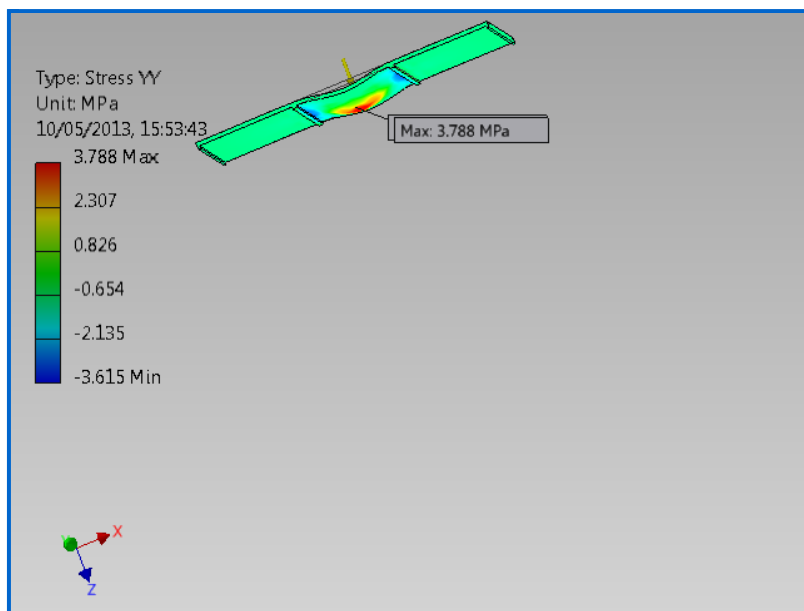
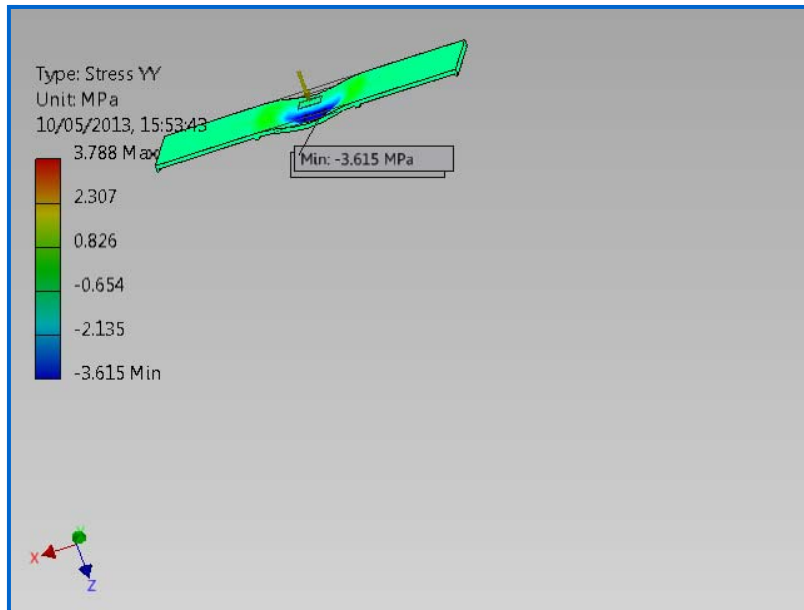

☐ Stress YZ

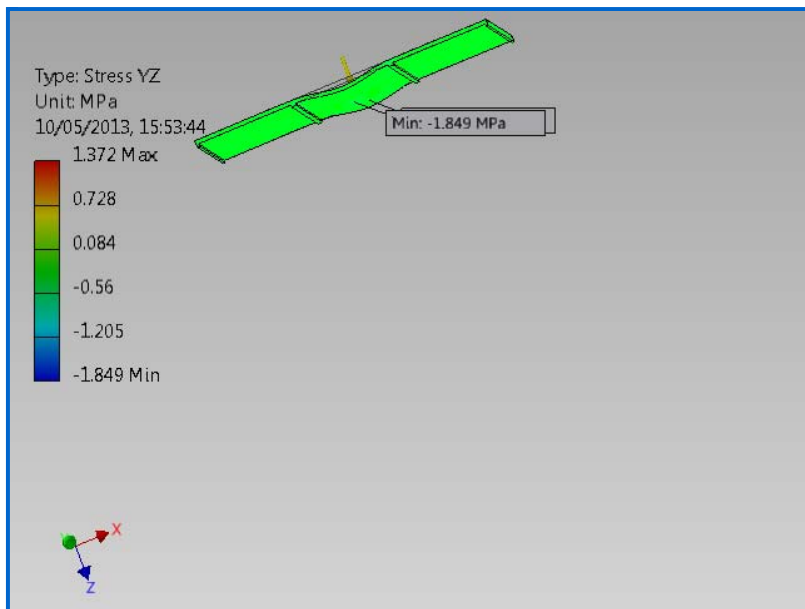
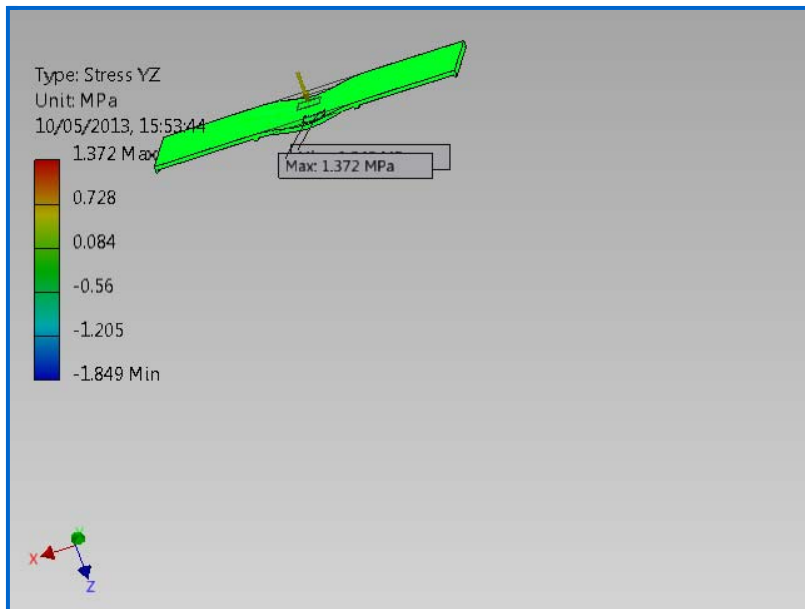

☐ Stress ZZ

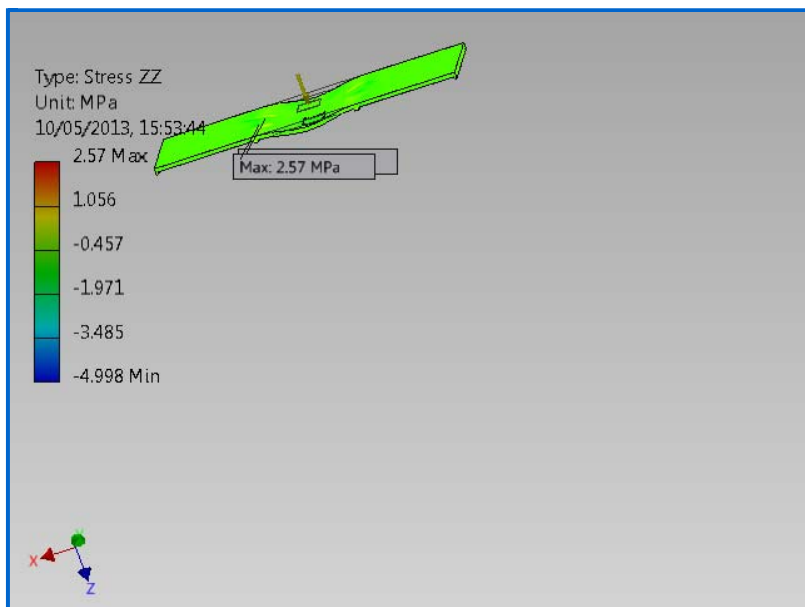

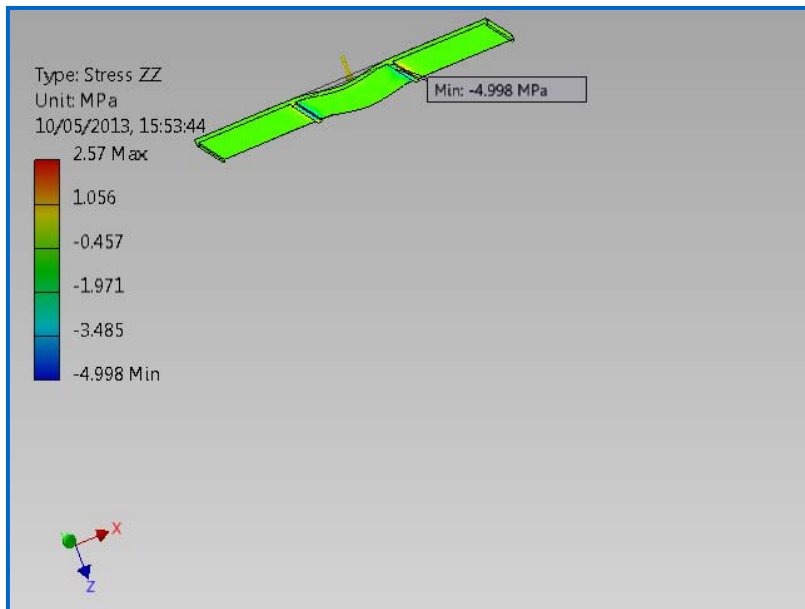

☐ X Displacement

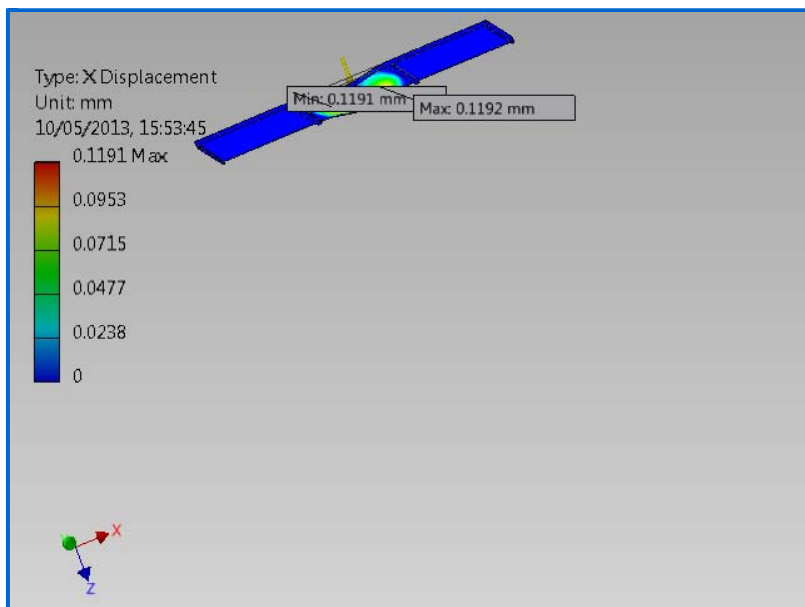
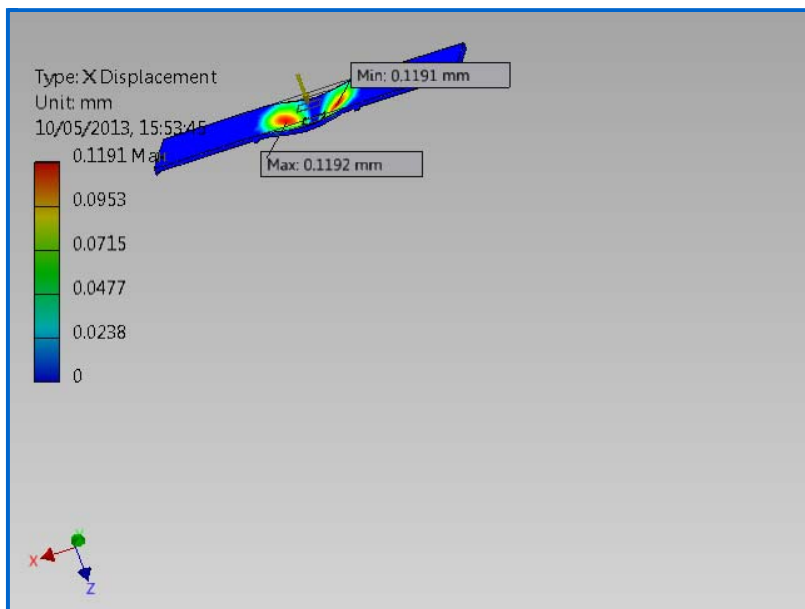

☐ Y Displacement

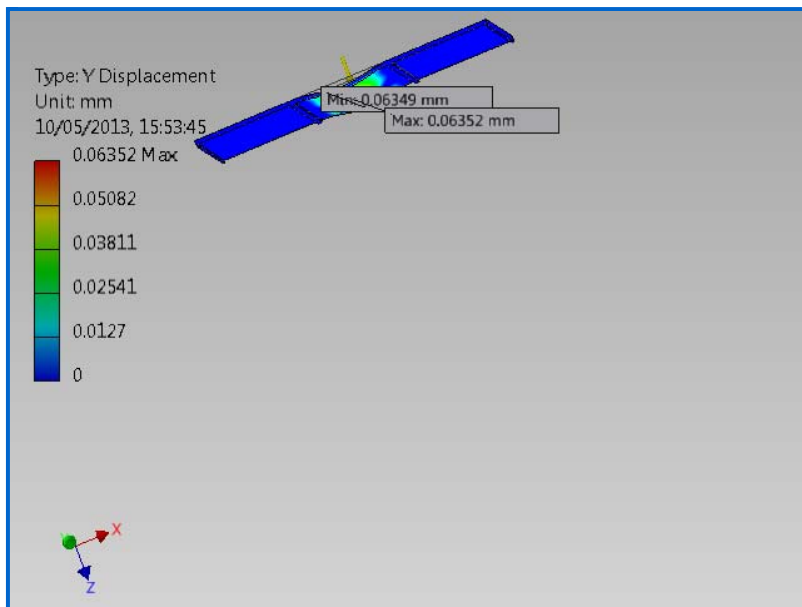
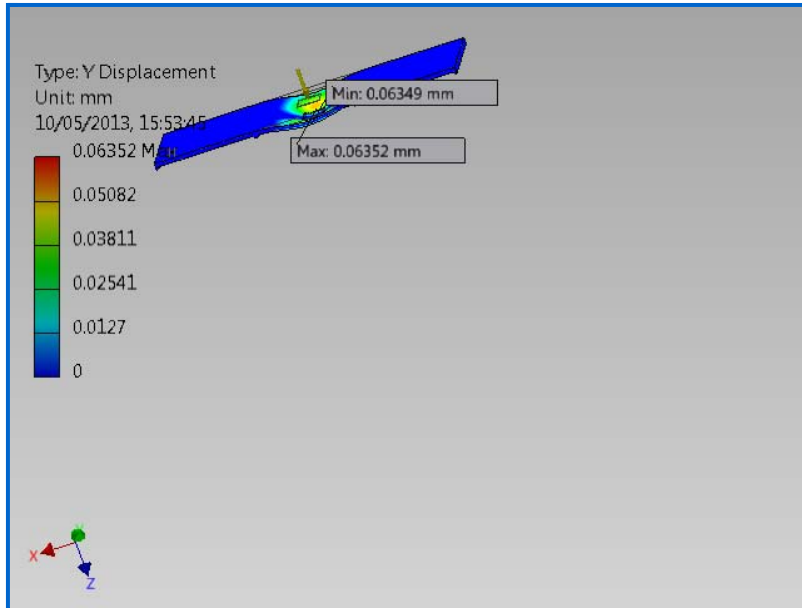

☐ Z Displacement

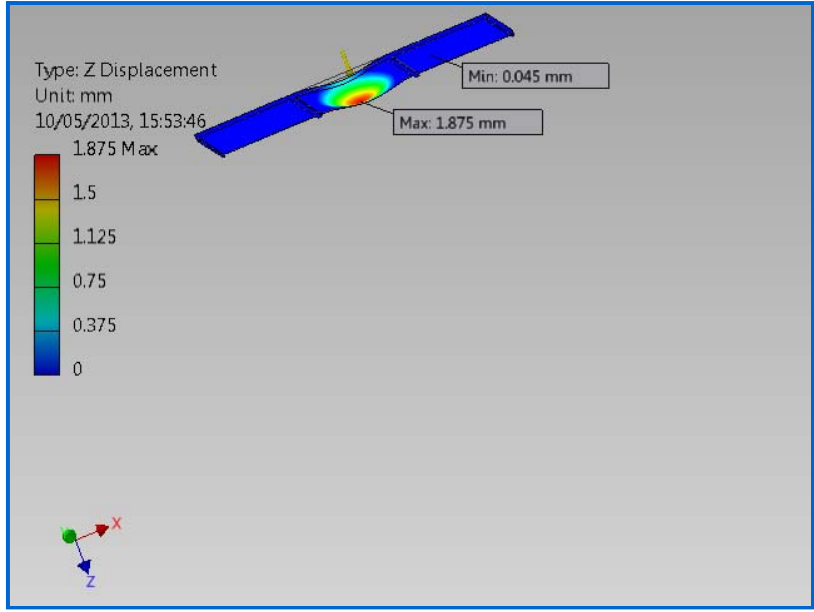
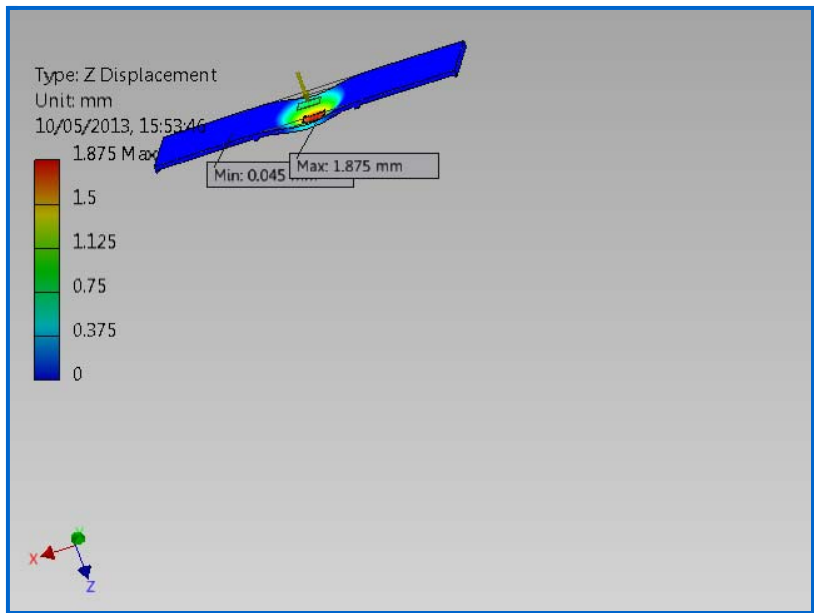

Equivalent Strain

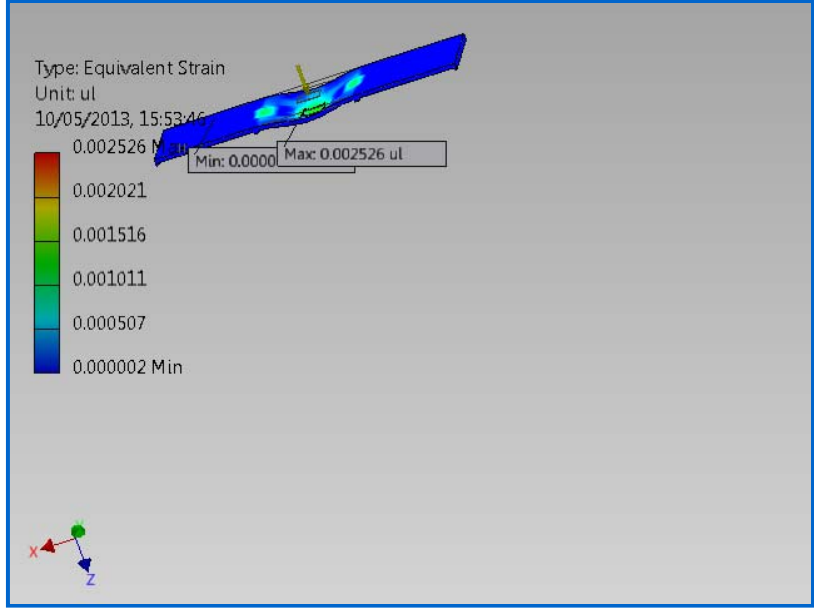

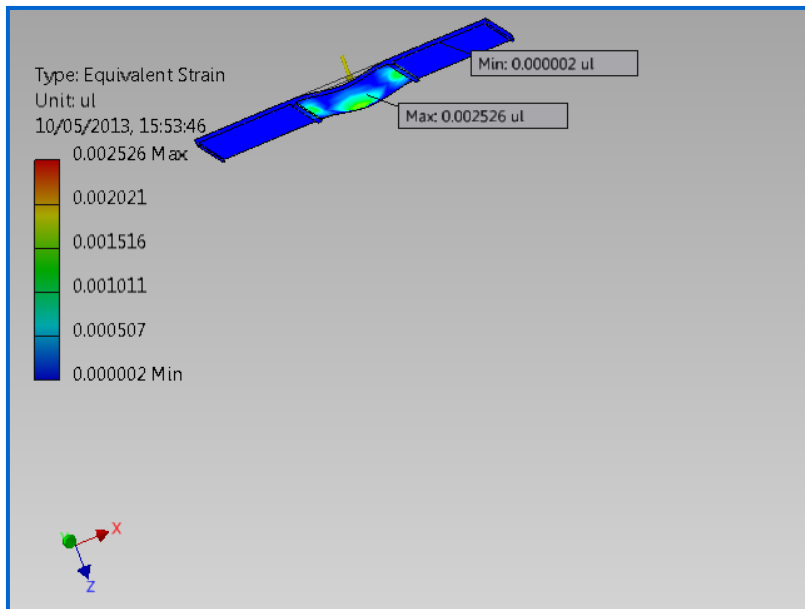

☐ 1st Principal Strain

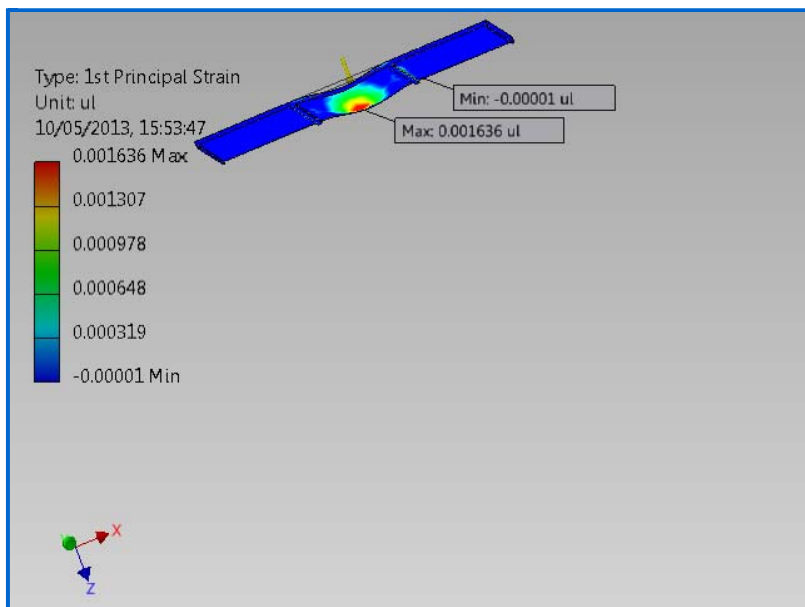
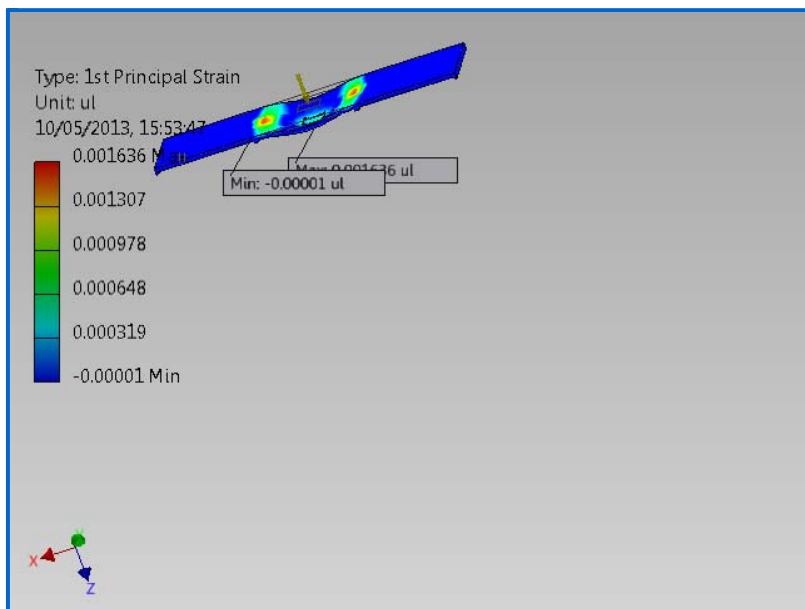

☐ 3rd Principal Strain

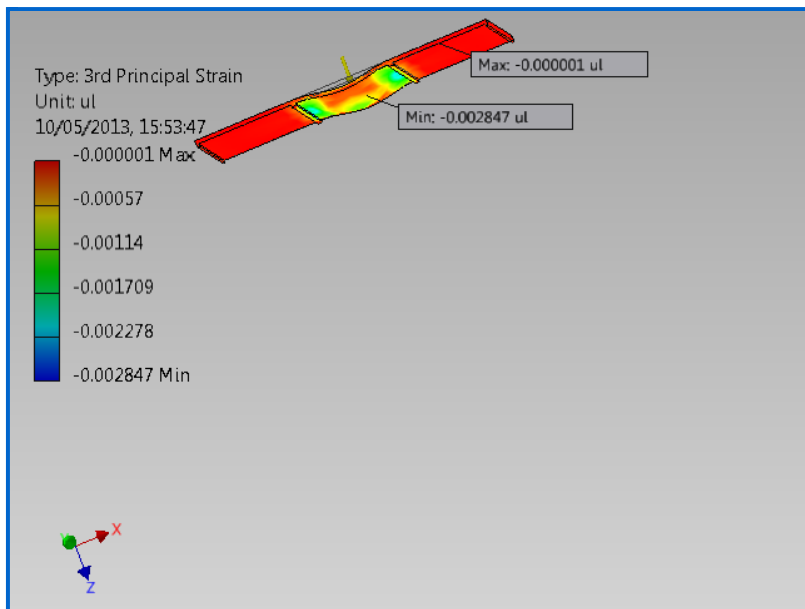
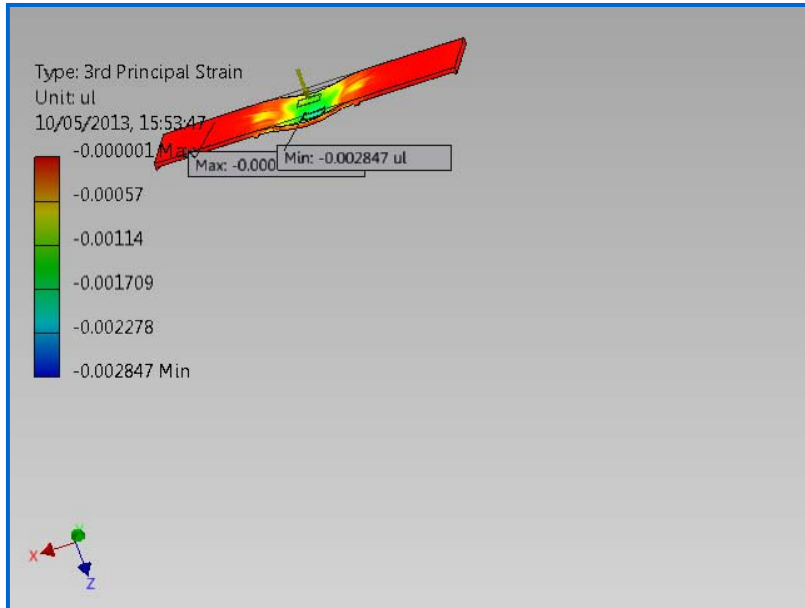

☐ Strain XX

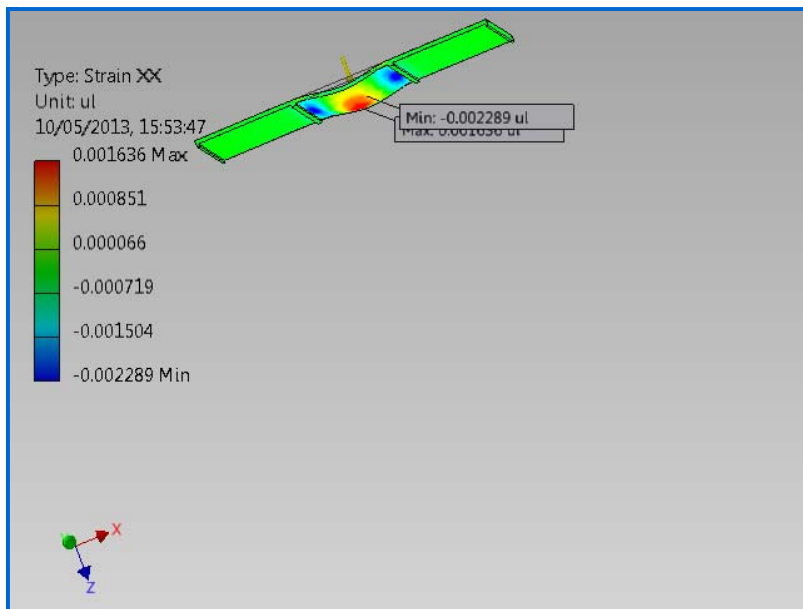
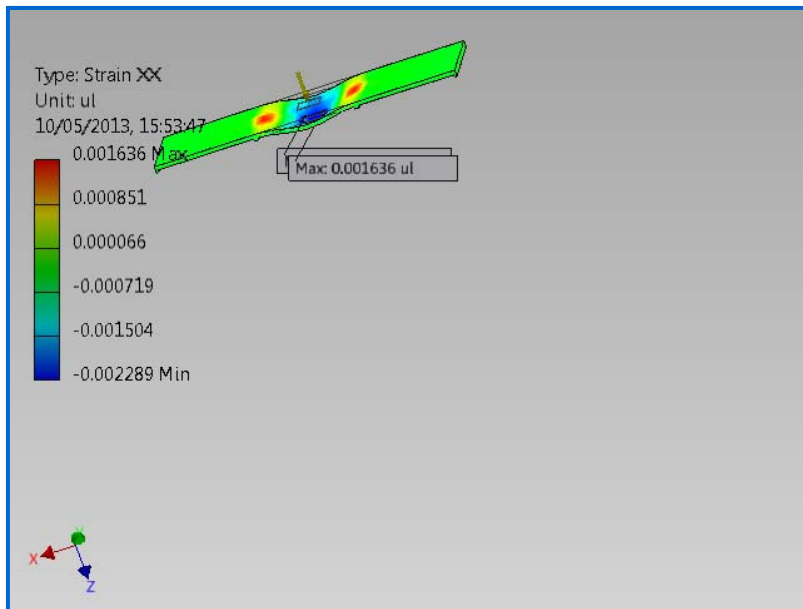

Strain XY

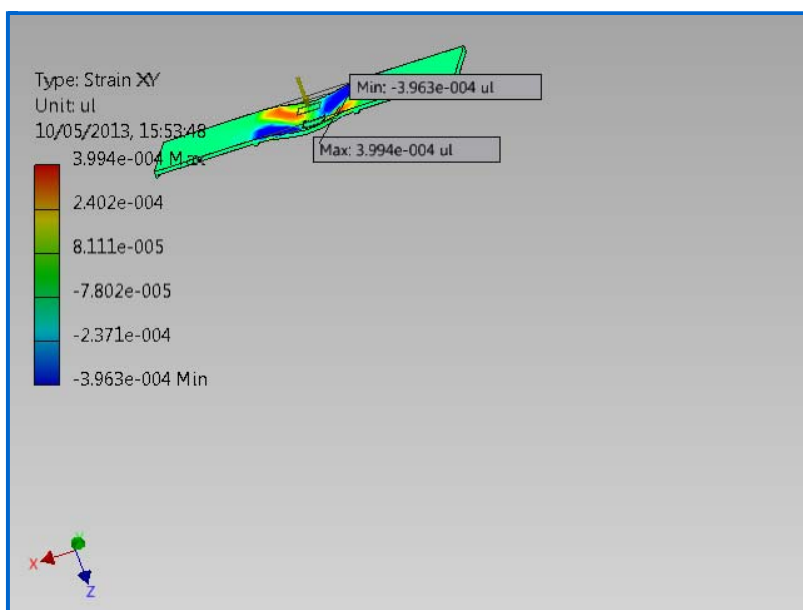

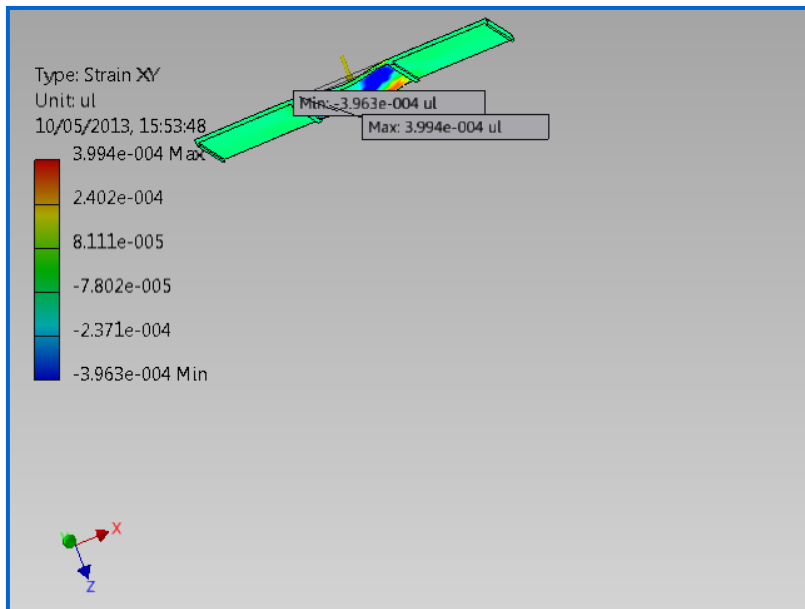

Strain XZ

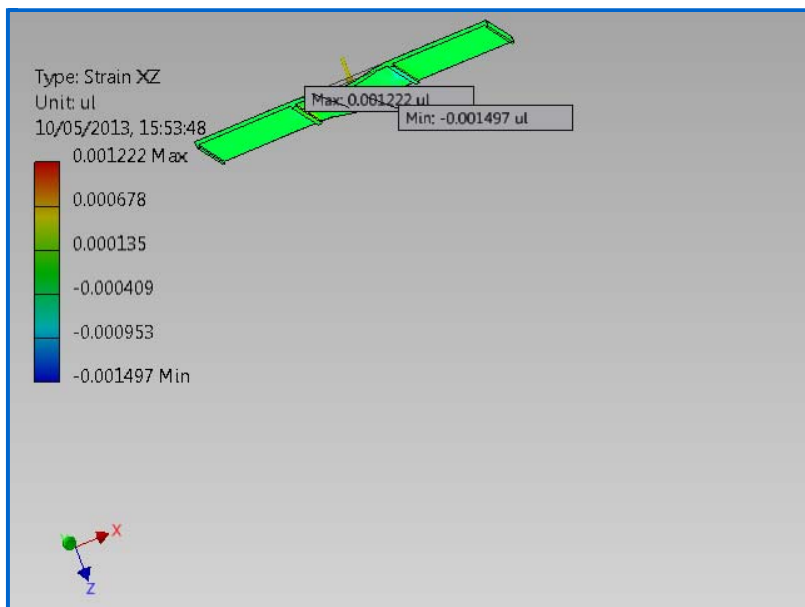
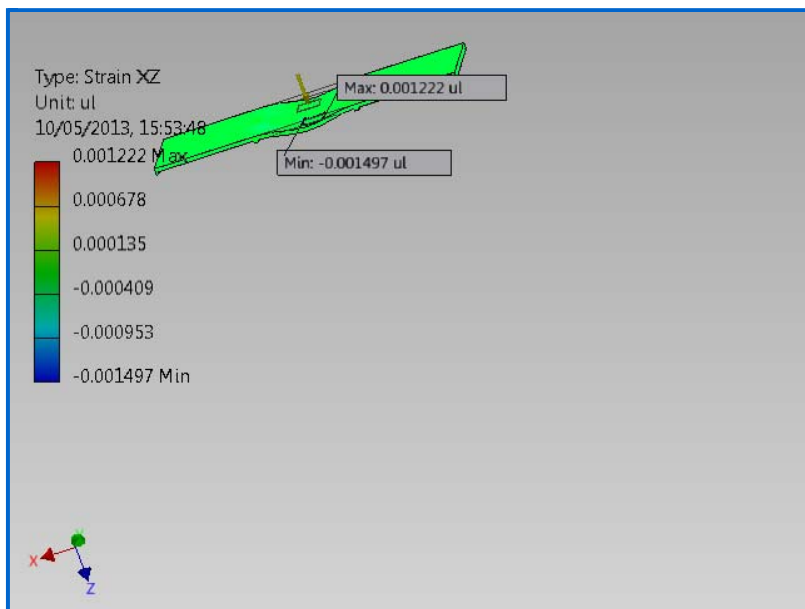

☐ Strain YY

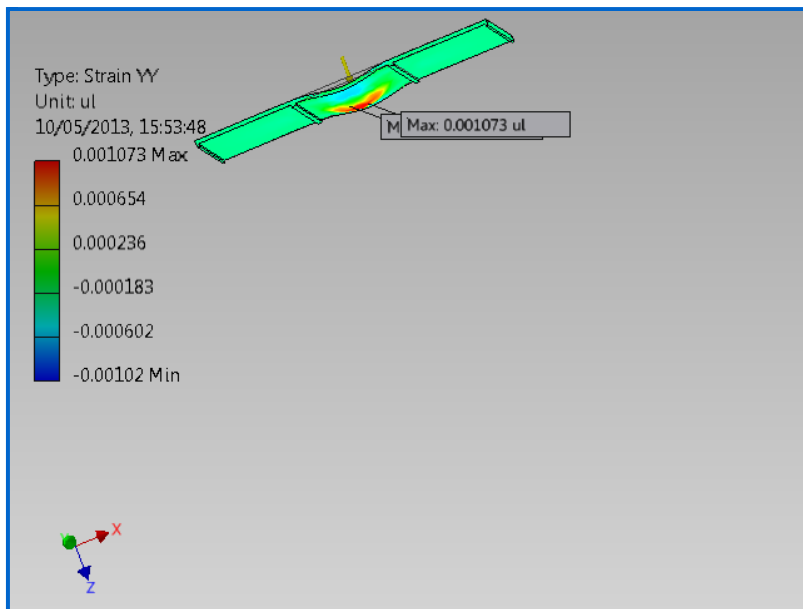
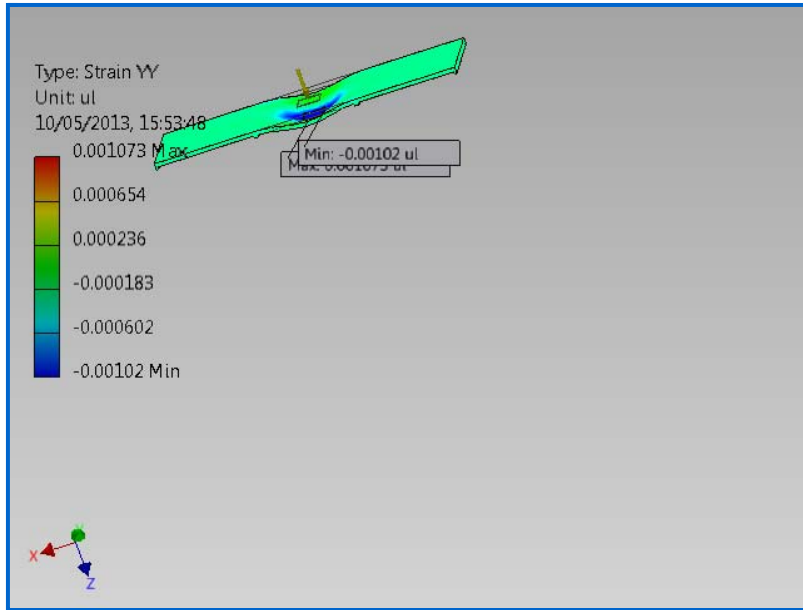

☐ Strain YZ

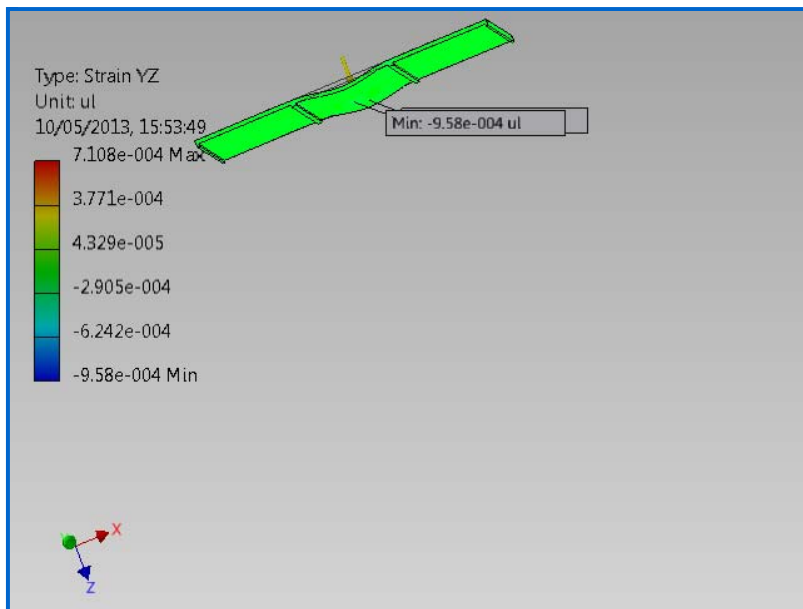
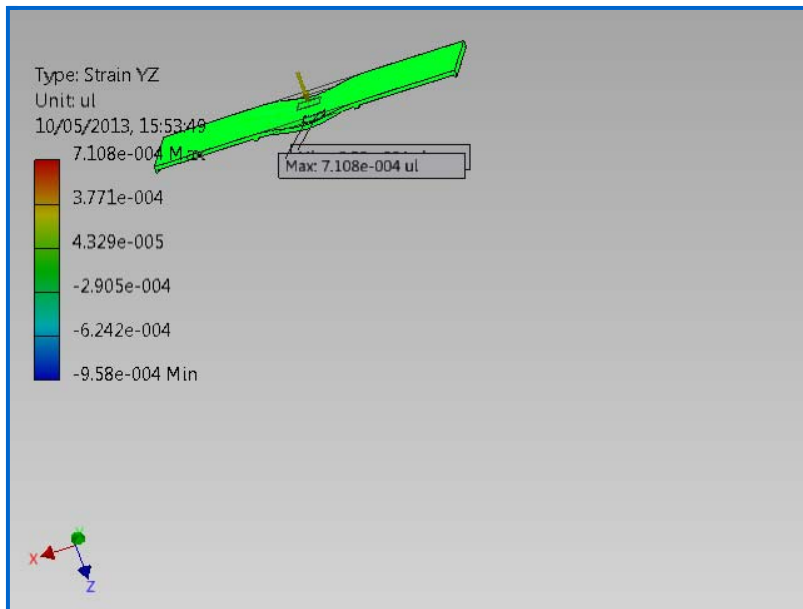

Strain ZZ

