

Steel Wall Installation

The building designer must ensure that load bearing walls have been designed:

- To resist all applied loads
- To be in accordance with AS4600, AS1684 and ASI720.1, the BCA and all relevant standards
- To assume no axial strength contribution from wall linings. Some wall systems will have their axial load capacities reduced. For steel, this is due to the steel weakening at temperature.

See figure 2.1 and 2.2 for installation details:

The following are important points to observe:

- Sheets are screw fixed, an optional full length 4mm bead of structural polyurethane or silicon adhesive can be used to the face of studs and noggings. ResCom BP does not recommend dabs of adhesives in installation.
- Due to indifferent metals such as screws and frame work MgO Corp recommends that a film of silicon, mastic tape or sarking is placed on the metal stud frame before fixing of the ResCom board to eliminate corrosion & moisture.
- It is important to install sheets from the corner outwards. Fix the sheet to the open side of the stud first to ensure misalignment of joints does not occur in vertical fixing applications.
- Where a double wall system is used, the gap between the walls should be from a minimum of 20mm to a maximum of 50mm.
- Control joints are used where specified, where dissimilar materials abut, or at least every 12 metres.

1. One layer ResCom[®] Board to each side of the wall.
2. Recommended stud spacing maximum 600mm centres on fire rated wall systems.
3. Bulk insulation may be required to achieve specified thermal, acoustic Rw+Ctr and R value performances.
4. On a firewall system do not fix the sheet to the bottom or top plates of the frame. As can be seen in figure 2.1 and 2.2, the screws or nails are 60mm from the top and bottom of the wall, one at each stud.
5. On sheet corners, keep the first screw/nail 50mm from the edge to avoid breakage of the sheet.
6. Fasteners at 12-15mm from sheet perimeter edges.
7. Screws will be class 3 to 5 (non corrosive) Minimum No. 8x40 self-drilling countersunk type fixed at maximum 300mm centres, and will finish at approximately 0.5mm below the surface. ResCom BP recommends in highly corrosive areas min grade 316 stainless steel non-corrosive fixtures.
8. Temporary fasteners through.
9. Keep the sheet 6mm from floor. Fill all joints, gaps and junctions with appropriate fire and acoustic sealant.
10. Where horizontal joints are not backed by noggings, stagger all horizontal joints 300mm minimum.
11. Stagger butt joints in adjacent sheets one stud minimum.
12. ResCom sheets can be laid vertical or horizontal.
13. Sheets can be joined mid span between studs by back blocking using 150mm width ResCom[®] board strips glued and fixed without loss of structural integrity.
14. Allow for appropriate expansion joints where and when needed.

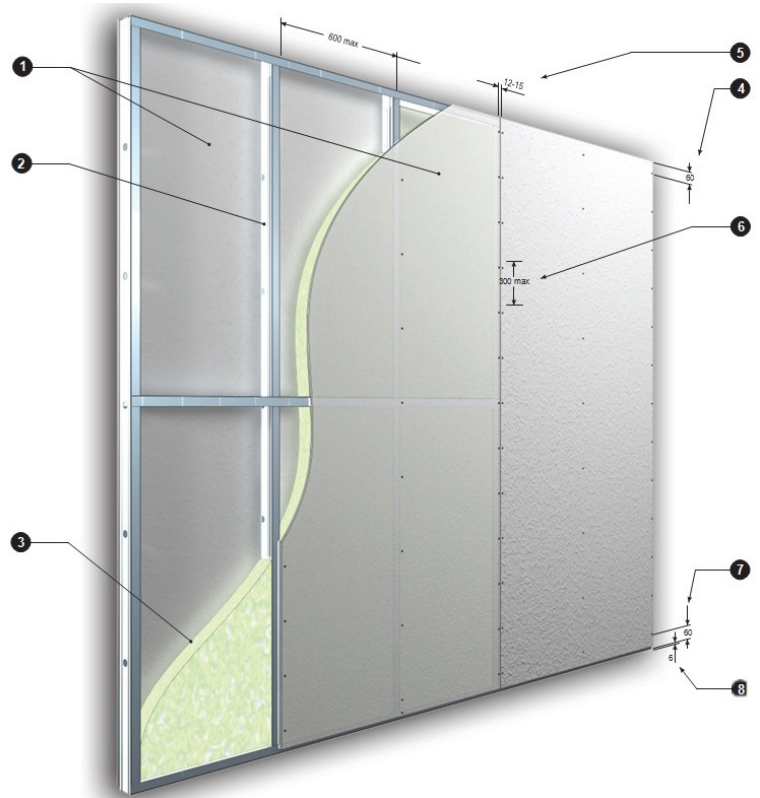

Figure 2.1 - Steel Fire Wall Installation Detail (Vertical)

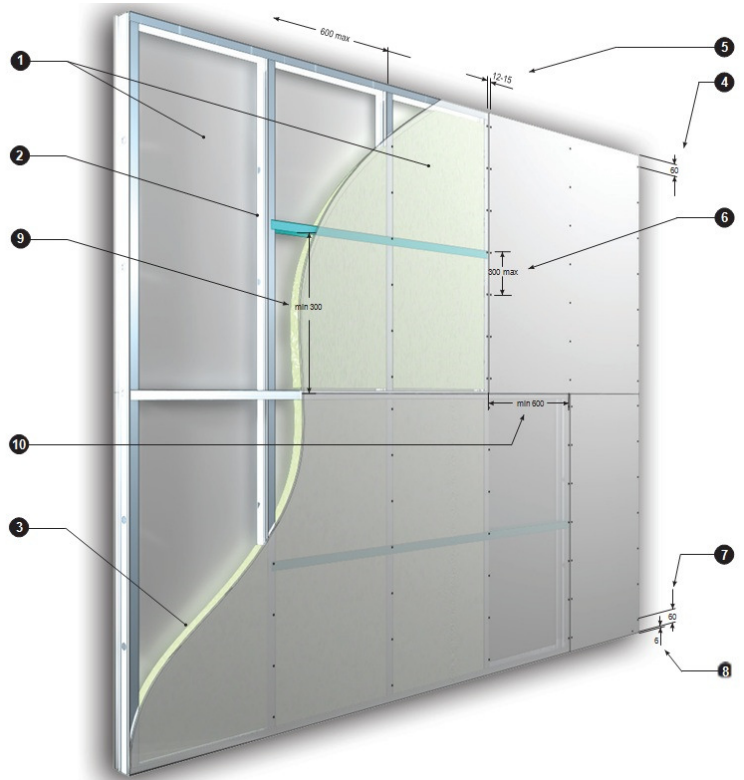
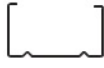

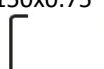

Figure 2.2 - Steel Fire Wall Installation Detail (Vertical)

Steel Frame Separation Walls

The size of steel stud should be determined by a professional engineer. The following is a guide to the maximum high of studs that can be used in non-loading situations.

ResCom® Thickness	Single Panel Performance	Single Panel on Stud	Single Panel Either Side of Stud: System Excl Acoustic Requirements
9mm	60 minutes	Non-loadbearing wall -/60/60 Loadbearing wall 60/60/60	Non-loadbearing wall -/60/60 Loadbearing wall 60/60/60 (Thermal Insulation Required in Cavity)
10mm	90 minutes	Non-loadbearing wall -/90/90 Loadbearing wall 90/90/90	Non-loadbearing wall -/90/90 Loadbearing wall 90/90/90 (Thermal Insulation Required in Cavity)
12mm	120 minutes	Non-loadbearing wall -/120/120 Loadbearing wall 120/120/120	Non-loadbearing wall -/120/120 Loadbearing wall 120/120/120 (Thermal Insulation Required in Cavity)
16mm	180 minutes	Non-loadbearing wall -/180/180 Loadbearing wall 180/180/180	Non-loadbearing wall -/180/180 Loadbearing wall 180/180/180 (Thermal Insulation Required in Cavity)
18mm	240 minutes	Non-loadbearing wall -/240/240 Loadbearing wall 240/240/240	Non-loadbearing wall -/240/240 Loadbearing wall 240/240/240 (Thermal Insulation Required in Cavity)
20mm Flooring	120 minutes	Loadbearing Floor 120/120/120	Loadbearing 120/120/120 (Thermal Insulation Required in Ceiling Cavity)

Stud Size	Maximum height for steel studs
64x0.75 	3150mm
76x0.75 	3600mm
92x0.75 	4175mm
150x0.75 	6150mm

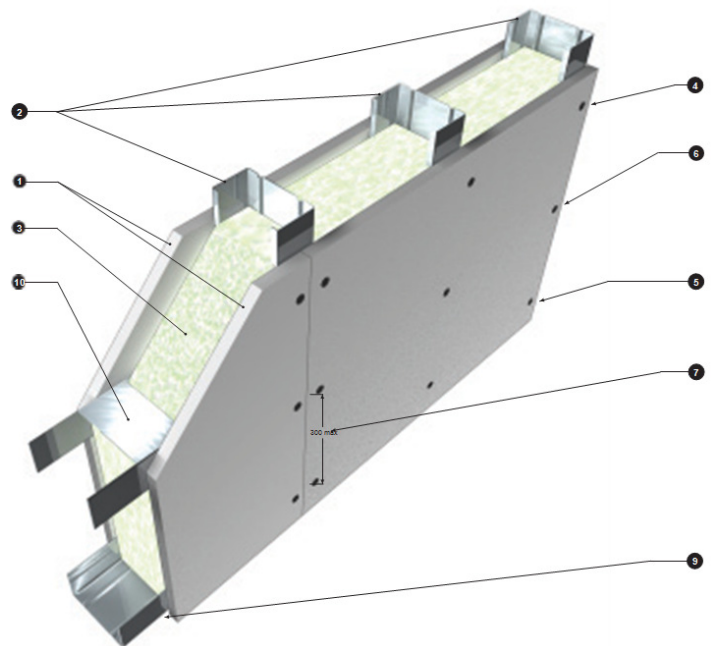

Figure 2.3.1 - Steel Fire Wall Single Board Each Side

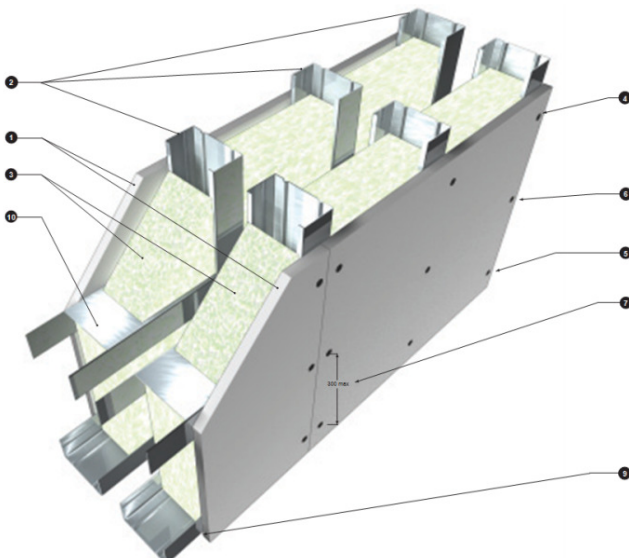

Figure 2.3.2 - Steel Fire Wall Double Stud Single Board Each Side

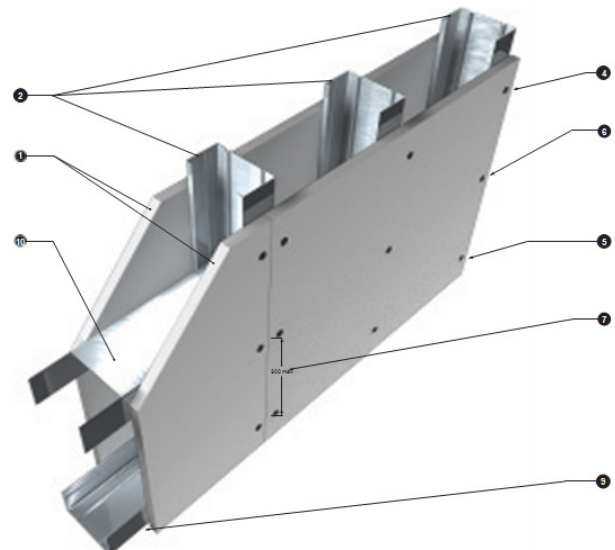

Figure 2.3.1.1 - Steel Fire Wall Single Board Each Side (no insulation - hoarding)